

GB SPIRAL MIXER
MODEL IM
Operating manual

F PÉTRIN À SPIRALE
MODÈLE IM
Manuel d'utilisation

D SPIRALTEIGKNETMASCHINE
MODELL IM
Bedienungsanleitung

IMPASTATRICE A SPIRALE | SERIE IM

MANUALE D'USO E MANUTENZIONE





SPIRAL MIXER | MODEL IM

OPERATING MANUAL



SUMMARY

CHAPTER 1 GENERAL INFORMATION	26
CHAPTER 2 INSTALLATION	33
CHAPTER 3 FUNCTIONING.....	35
CHAPTER 4 USAGE	38
CHAPTER 5 MAINTENANCE	41
CHAPTER 6 DEMOLITION OF THE MACHINE.....	43
CHAPTER 7 AFTER SALE SERVICE	44

Prefix

This manual is specifically for the installation, use and maintenance of spiral mixers. So you are able to use the product in the best way. It is important that the manual is kept in good condition and should stay with the machine at alltimes, including sale to another person, for security in the use of the machine.

The manufacturer is not under any obligation to notify of any further modification of the product.

All rights of this document are reserved and no alternation or reproductions can be made without permission of the manufacturer.

The following symbols are included to better stress some passages:

 **WARNING:** indicates hazards that may cause serious damages; attention is required.

 **INFORMATION:** indicates particularly important technical information.

CHAPTER 1 | GENERAL INFORMATION

1.1 Warranty

Guaranteed for 2 years from date of purchase. The date must be stamped on the guarantee on the date of purchase. Parts of the machine found to be a production defect except electrical components or parts worn out, will be changed and serviced free by us in our firm but only ex our factory within this period. Delivery expenses and costs of labour are excluded from the warranty.

The warranty will not be valid when the damage is due to: transportation, mistaken or insufficient maintenance, unskilled operators, damaging, repairs made by unauthorized personnel, non-observance of the instructions of the manual.

All reimbursements from the manufacturer are excluded for direct or indirect damages caused in the time the machine is inactive for the following reasons: breakdown, waiting to be repaired, or anyway the nonpresence of the machine.

1.2 Characteristics of the machine

The mixers in the models with fixed top and bowl or with raising top and removable bowl were made with the intention for food usage only, to mix doughs made by cereal flours, for the prevalent use in: pizza-restaurant, bread and bakery shops.

Every mixer (PICT. 1) is composed of:

- A steel structure protected by a heat resistant varnish.
- The bowl, the spiral, the central doughbreaker and the protection grate are all in stainless steel.
- Chain drive with oilbath gearmotor.
- The moving parts are on ball bearing.
- Type feet (from models IM 5 and IM 8), set of wheels (for models from IM 12 to IM 44), type feet in stainless steel and wheels in nylon (for IM 60)
- Operation with single-phase or threephase motor, one speed; on request: threephase motor with two speeds and timer (apart from models IM 5 and IM 8).
- Electric circuit fed by a cable to the network to which are connected at low tension (24V) the control devices to start, to stop, and of the safety devices. Among these l'internal blocking of the moving parts activated by the movement of the mobile protection of the pan.

PICT. 1

IM 5; IM 8

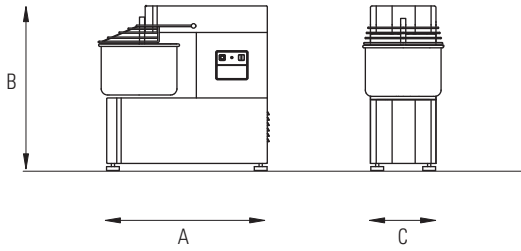

IM 12; IM 18; IM 25; IM 38; IM 44

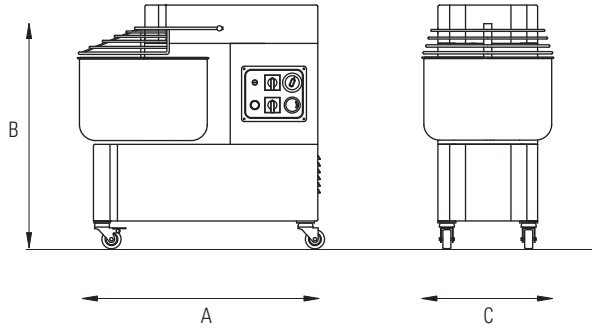

**IM 12A; IM 18A; IM 25A;
IM 38A; IM 44A**

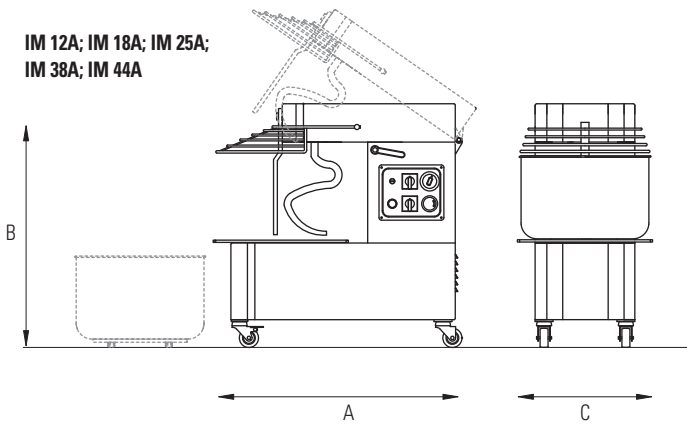

1.3 Technical characteristics

	Model	Kneading capacity Kg	Flour capacity Kg	Bowl volume Lt	Bowl dimension mm	Motor power Kw	Volt	Dimensions mm A C B	Weight Kg
	FIXED HEAD AND FIXED STEEL BOWL	IM 5M	5	3	7	237 x 160	0,37	230/50	540 x 260 x 527
IM 5T		5	3	7	237 x 160	0,37	400/50/3	540 x 260 x 527	33
IM 8M		8	5	10	260 x 200	0,37	230/50	550 x 280 x 555	36
IM 8T		8	5	10	260 x 200	0,37	400/50/3	550 x 280 x 555	36
IM 12M		12	8	15	317 x 210	0,9	230/50	675 x 350 x 690	60
IM 12T		12	8	15	317 x 210	0,75	400/50/3	675 x 350 x 690	60
IM 12D		12	8	15	317 x 210	0,6/0,8	400/50/3	675 x 350 x 690	60
IM 18M		18	12	20	360 x 210	0,9	230/50	697 x 390 x 690	65
IM 18T		18	12	20	360 x 210	0,75	400/50/3	697 x 390 x 690	65
IM 18D		18	12	20	360 x 210	0,6/0,8	400/50/3	697 x 390 x 690	65
IM 25M		25	17	33	400 x 260	1,1	230/50	762 x 430 x 770	95
IM 25T		25	17	33	400 x 260	1,1	400/50/3	762 x 430 x 770	95
IM 25D		25	17	33	400 x 260	1/1,4	400/50/3	762 x 430 x 770	95
IM 38M		38	25	40	452 x 260	1,5	230/50	818 x 480 x 770	105
IM 38T		38	25	40	452 x 260	1,5	400/50/3	818 x 480 x 770	105
IM 38D		38	25	40	452 x 260	1,5/2,2	400/50/3	818 x 480 x 770	105
IM 44M		44	30	50	500 x 270	1,5	230/50	842 x 530 x 770	110
IM 44T		44	30	50	500 x 270	1,5	400/50/3	842 x 530 x 770	110
IM 44D	44	30	50	500 x 270	1,5/2,2	400/50/3	842 x 530 x 770	110	
IM 60M	60	40	75	550 x 370	2,6	230/50	1020 x 575 x 1010	250	
IM 60T	60	40	75	550 x 370	2,6	400/50/3	1020 x 575 x 1010	250	
IM 60D	60	40	75	550 x 370	2,6/3,4	400/50/3	1020 x 575 x 1010	250	

LIFTABLE HEAD AND EXTRACTIBLE STEEL BOWL	IM 12AM	12	8	15	317 x 210	0,9	230/50	690 x 350 x 690	80
	IM 12AT	12	8	15	317 x 210	0,75	400/50/3	690 x 350 x 690	80
	IM 12AD	12	8	15	317 x 210	0,6/0,8	400/50/3	690 x 350 x 690	80
	IM 18AM	18	12	20	360 x 210	0,9	230/50	715 x 390 x 690	85
	IM 18AT	18	12	20	360 x 210	0,75	400/50/3	715 x 390 x 690	85
	IM 18AD	18	12	20	360 x 210	0,6/0,8	400/50/3	715 x 390 x 690	85
	IM 25AM	25	17	33	400 x 260	1,1	230/50	780 x 430 x 770	115
	IM 25AT	25	17	33	400 x 260	1,1	400/50/3	780 x 430 x 770	115
	IM 25AD	25	17	33	400 x 260	1/1,4	400/50/3	780 x 430 x 770	115
	IM 38AM	38	25	40	452 x 260	1,5	230/50	838 x 480 x 770	130
	IM 38AT	38	25	40	452 x 260	1,5	400/50/3	838 x 480 x 770	130
	IM 38AD	38	25	40	452 x 260	1,5/2,2	400/50/3	838 x 480 x 770	130
	IM 44AM	44	30	50	500 x 270	1,5	230/50	878 x 530 x 770	140
	IM 44AT	44	30	50	500 x 270	1,5	400/50/3	878 x 530 x 770	140
IM 44AD	44	30	50	500 x 270	1,5/2,2	400/50/3	878 x 530 x 770	140	

M= Single-phase Motor T= Three-phase Motor D= Three-phase Motor 2 speeds

1.4 Electrical schemes

SINGLE-PHASE CONNECTION IM 5-8 M

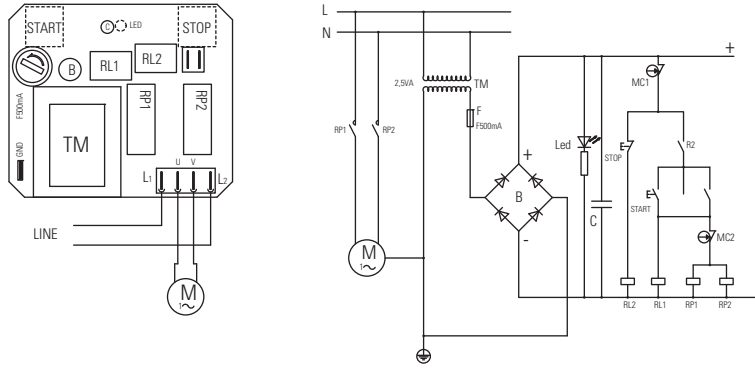

SINGLE-PHASE CONNECTION IM 12-18-25-38-44 M

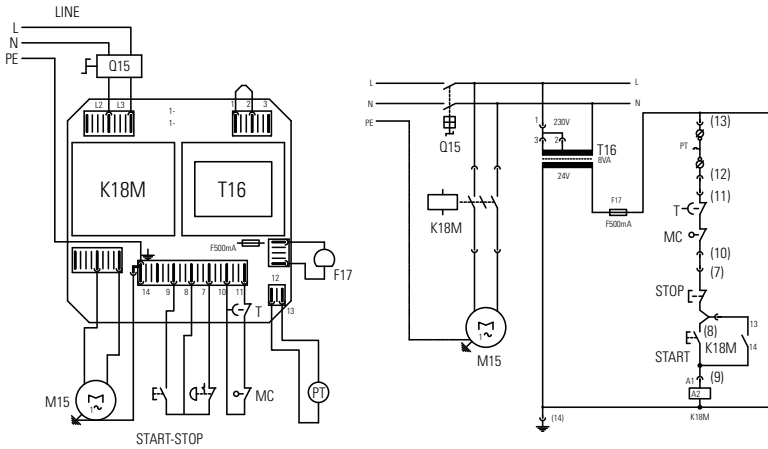

ENGLISH

THREE-PHASE CONNECTION IM 12-18-25-38-44-60 T

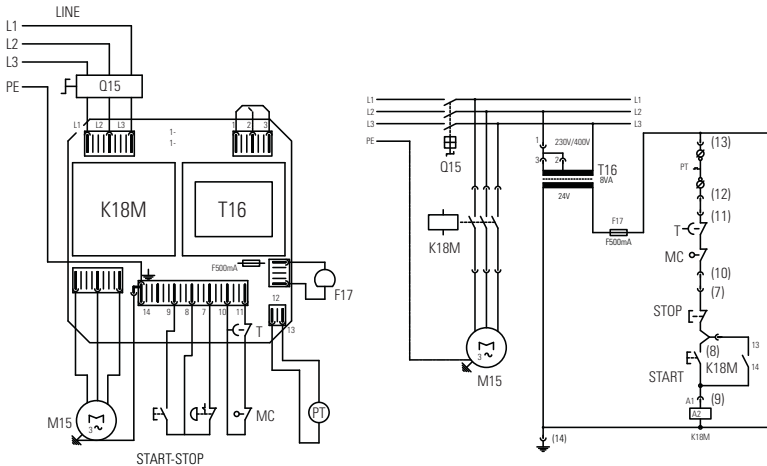

THREE-PHASE CONNECTION 2 VEL. IM 12-18-25-38-44-60 D

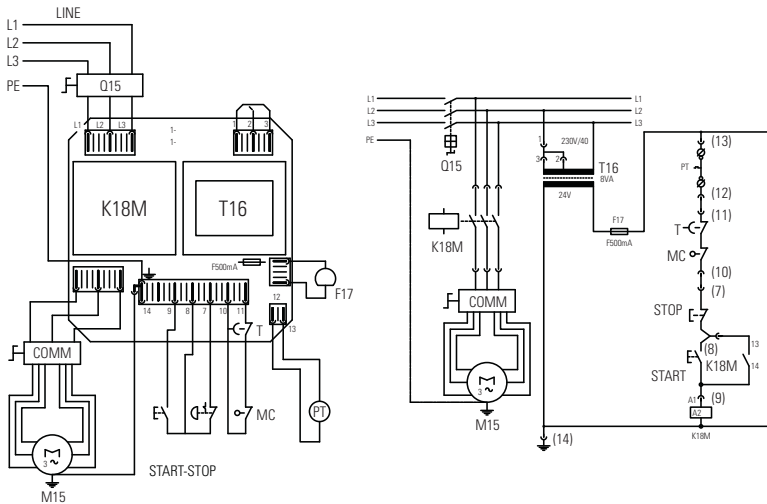

Electrical schemes

SINGLE-PHASE AND THREE-PHASE CONNECTION

IG	=	General switch
T16	=	Transformer
F17	=	Fuse
PT	=	Thermoprotection of the engine
FC	=	Safety photocell
MC	=	Safety limit switch
STOP	=	Stop button
START	=	Operating button
K18M	=	Contacteur
LI	=	Operating light
M	=	Engine

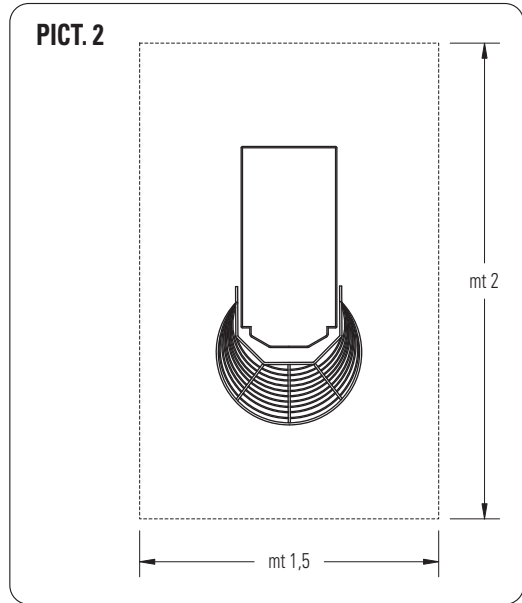

1.5 Operating area

In normal working conditions and to have the best exploration of the potentiality of the machine, the operator needs the area represented in PICT. 2.

1.6 Security indications

Although the machine is built in conformity to the required security rules regarding electrical, mechanical and hygienic regulation it can be dangerous if:

- Used in case and condition different to those described by the manufacturer.
- Manomission of the protection and of the safety devices.
- Inattention to the instruction of: Installation - Functioning - Usage - Maintenance.

i INFORMATIONS

Installation and maintenance have to be done by qualified personnel authorized by the manufacturer who is not responsible for any mistaken installation or manomission.

1.7 Security indications

i INFORMATION

Carefully read the instruction before using the machine.

⚠ WARNING

The avoid dangerous condition and/or possible injuries caused from: electric current, mechanical parts, fire or hygienical problems, you must follow the security indications step by step.

- A) Keep in order your working area. Disorder can cause dangerous accidents.
- B) Consider environmental conditions. Do not use the machine in humid, wet or nadly lit environments, close to inflamable liquids or gas.
- C) Keep away from children and non authorized personnel. Do not permit them to go near the machine or the working area.
- D) Only utilize the machine with the correct voltage. Normal usage gives better results.
- E) Dress in adequate way. Do not wear hanging clothes or any items which can be caught in the machine. Use non-slip shoes. For hygiene and safety keep your hair tied back and wear protective gloves.
- F) Protect the cable. Do not pull the cable to extract the plug. Do not leave the cable near high temperatures, sharp objects, water or solvents.
- G) Avoid insecure positions. Find the best surface to ensure the machine is balanced.
- F) Always pay maximum attention. Do not be distracted when using the machine.
- I) Take the plug out. When the machine is not in use, before cleaning, maintenance and moving it.
- L) Do not use further extensions.
- M) Check that the machine is not damaged. Before using the machine carefully check that all security devices are working. Check that: the mobile parts are not blocked, there are not any parts damaged, all the parts have been set up correctly and all the conditions that could influence the regular functioning of the machine are in working order.
- N) Repairing the machine by qualified personnel. The repairs can only be done by qualified people, using original spare parts. The non- compliance with these rules can represent danger for the user.

CHAPTER 2 | INSTALLATION

2.1 Instructions for the user

The environmental conditions in which the machine must be installed must follow these characteristics:

- Be dry
- The machine is constructed to have IPX1 protection level.
- Water and heat sources at safe distance
- Adequate ventilation and lighting corresponding to hygiene and security regulations following the existing laws. The surface should be flat and compact for easier cleaning. For normal ventilation of the machine no objects should obstruct.

INFORMATION

The electric network must be provided with an automatic differential switch having characteristics suitable to those of the machine, in which the opening distance between the contacts must be of at least 3 mm. Most of all it is necessary a good ground system.

WARNING

Verify that the electrical set-up corresponds with the numbers of the technical characteristics (1.3) found and on the small plate at the back of the machine.

2.2 Installation methods

The machine is supplied in a closed package and fixed with metal straps on wood. Inside the packaging with the machine you will find the instructions and the declaration of conformity according to the machines regulation. The machine must be unloaded and lifted out at the part indicated on the packaging by proper equipment. For the transportation of the machine to the place of installation, use a fork lift.

After cutting the metal straps take out of the packaging and the plastic cover, then with the help of a proper belt put under the machine (PICT. 3) and a fork lift (manual or motor) lift the machine and take away the bottom pallet, position the machine making sure you leave a space around it of 50 cm to make usage, cleaning and maintenance easier. If the machine is unstable put under the feet or wheels pieces of hard rubber. If the machine has wheels make sure they have been blocked by pushing the lever A downwards till it blocks (PICT. 4).

Note: All packaging must be disposed of in a lawful way.

PICT. 3

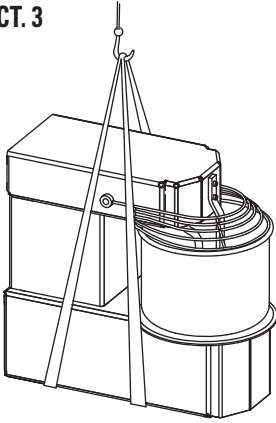

PICT. 4

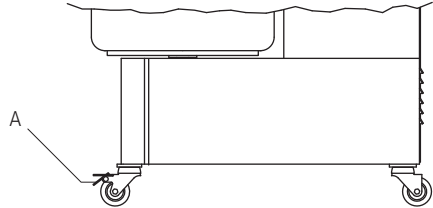

2.3 Electrical connections

The connections type Y of the machine with the electric network is made by means of an operation cable, which is provided with a plug only in the singlephase model. As far as the three-phase machines are concerned it is necessary to put together the cable and a normalized and polarized plug (the distinction between phase and neutral must be unequivocal), and verify that the rotation way of the bowl is the same indicated by the arrow on the bowl.

2.4 Positioning of the machine

The plug must be easily accessible, must not require any kind of movement. The cable from the machine to the wall plug must not be pulled tightly, also do not rest the machine on the cable.

CHAPTER 3 | FUNCTIONING

The machines are provided with the following operating and safety devices:

3.1 Operating devices

Single-phase or Threephase machines (IM 5 - IM 8) (PICT. 5):

A - Green button 1 operating

B - Red button 2 Stop

Single-phase or Three-phase machines (the rest of the models) (PICT. 6-7):

C - General switch

D - Green button: Operating

E - Red button: Emergency stop

F - Timer

G - Fuse

H - Speed commutator

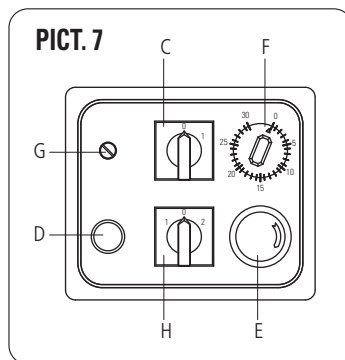
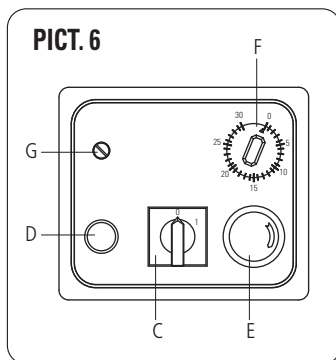
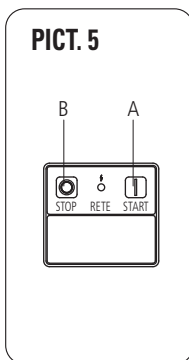

3.2 Safety devices

I - Moving protection grate (PICT. 8)

L - Device proving that the top and the protection cover are up or down

M,M1 - Check pin of the top (down position)

N - Device proving that the bowl is in or out

O - Blocking disk of the bowl

Note: The safety devices M,M1-N-O can be found only in the machines with raising top and removable bowl (A models). The device proving that the protection cover is up or down is located inside the head of the machine on the models with fixed top.

ENGLISH

⚠ WARNING

The single safety device are efficient when:

- On raising the protection I (PICT. 8) the machine stops.
- On raising the top (by means of the check pin M and/or taking off bowl the machine does not start.
- On softly pulling either the bowl or the top they do not move.

Before operating the machine, the protection I (PICT. 9) must be completely lowered. In the A models it must be checked that the bowl is correctly inserted and blocked by the disk O and that the top is down and blocked by the check pin M (this must be completely inserted). After inserting the plug the machine is ready for use.

PICT. 8

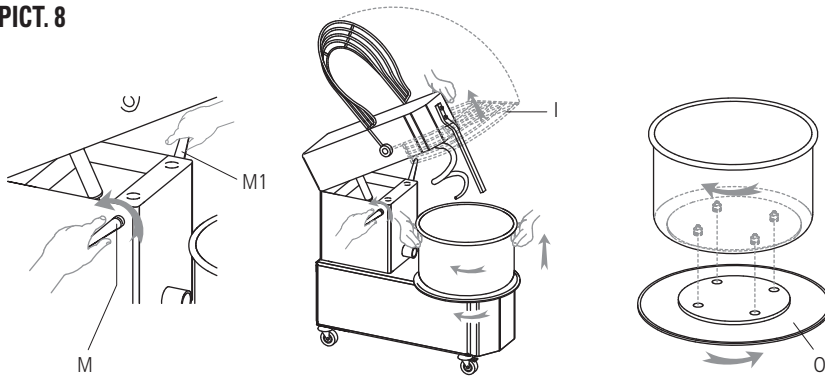

PICT. 9

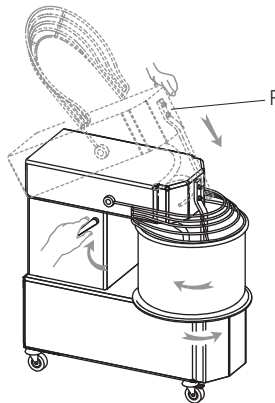

3.3 Working test machine

Single-phase or three-phase machine (mod. IM 5 - IM 8):

OPERATING: push the green button A to start the bowl and the spiral.

STOP: push the red button to stop the bowl and the spiral.

Single-phase or three-phase machine (1-2 vel.) (from mod. IM 12 to mod. IM 60)

OPERATING: rotate the knob of the switch C in position 1, set the time of mixing by the timer F, push the green button D to start the bowl and the spiral.

STOP: rotate the knob of the switch C in position 0, or push the red button E to stop the bowl and the spiral. In order to operate the machine again after the stop due to the raising of the protection I or to the activating of the emergency button E it is necessary to proceed as follows: lower again and completely the protection I; release the button E by rotating in clockwise, as shown by the arrow, and push the operating button D.

Note: In a machine fed electrically by three-phase, if the rotation of the bowl is opposite the way shown by the arrow it is necessary to follow these indications for the functioning and every time you change the electric plug:

- Stop the machine.
- Take the plug out.
- Reverse on the plug the position of two phases (example: L1 with L2 and vice versa).
- Restart the machine and verify if the bowl is rotating the right way.

Start the machine without using it, let it on for about one minute and verify that it is functioning perfectly.

CHAPTER 4 | USAGE

Before starting work make sure that the machine is perfectly clean in particular, the surfaces of bowl, the spiral and of the central column that have contact with the food products. If necessary clean them following indications at 5.1.

4.1 Usage of the machine with fixed top and bowl

After lifted up the protection I, pour in the bowl all the required ingredients, push down the protection, press the button to start A or D. The movement made by the spiral, which is sincronized with the rotation of the bowl, gives an amalgamation of, flour, water, salt, yeast and other eventual ingredients till you obtain a mixture of the consistence required. If necessary, in order to modify the characteristics and/or the consistence of the initial dough, pour the ingredients through the protection grate I. When work cycle is completed, leave machine on hold, lift up the mobile protection to maximum opening, take mixture out of the bowl, proceed with cleaning of the machine following the indications at 5.1.

4.2 Usage of the machine with raising top and removable bowl

The machine with raising top and removable bowl, is functionally identical to the machine with fixed top and bowl.

It differentiates from the other only for the following advatages, that it can offer at the end of each work cycle:

- The facility in the collection of the dough.
- The facility in the cleaning phase.

4.2.1 Raising of the top and taking off of the bowl

In order to raise the top and to take off the bowl proceed ad follows: stop the machine, unplug the machine, raise the protection I completely (PICT. 10), pull the pin M as far as the top is blocked, raise the top by means of the little piston underneath, rotate clockwise the disk O as far as the bowl is unlocked, raise the bowl and take it off, take off the dough.

PICT. 10-11

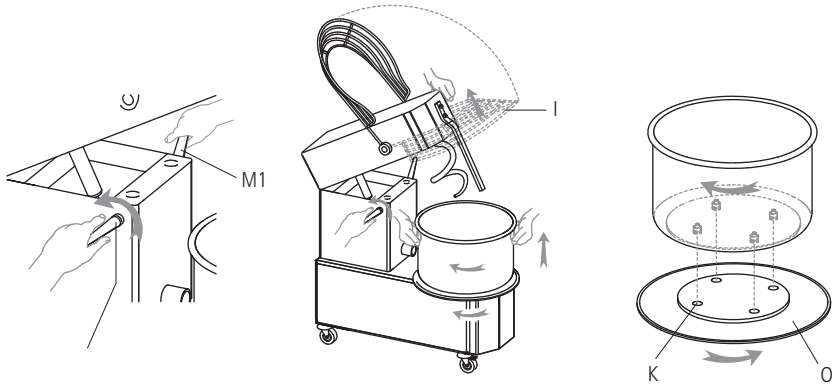

4.2.2 Repositioning of the bowl and top

Once the cleaning is done, put the bowl back on, and make sure that the four pins underneath (PICT. 11) are correctly fixed in the four holes K of the machine; then block the bowl rotating clockwise the disk O. Put the top down pushing it downwards (PICT. 9) as far as it is blocked by the pin M.

4.3 Usage of the machine with two speeds

OPERATING: Rotate the knob of the switch C in position 1 (PICT. 7), select speed 1 or 2 by rotating the knob of the selector H, push the green button D to operate both the bowl and the spiral. In order to change the speed of rotation of the machine, rotate the knob H from position 1 to 2 or vice versa. After each change of speed push the button D.

STOP: Rotate the knob of the switch C in position 0, or push the red button E to stop both the bowl and the spiral.

4.4 Usage of the machine provided with timer

The timer is an electromechanical device that allows to program from 1 to 30 minutes.

- The work-time of the machine by rotating the knob 0 in the desired position (PICT. 13).
- Operate the machine following the instructions of par. 3.1 or 3.2 or 4.3.
- Once the set time is over, the timer stops the machine.

i INFORMATION

Before taking off the dough beware of following the stop procedure of par 3.1 or 3.2.

CHAPTER 5 | MAINTENANCE

⚠ WARNING

Before effecting any kind of maintenance or cleaning you must take out the plug. In any case of malfunctioning or damage of the machine you must apply for authorized assistance from the manufacturer (see Chapter 7).

5.1 Cleaning

The cleaning must be done every time the machine has been used following all the rules to prevent malfunctioning of the machine and for hygienic purposes. Using a wooden or plastic palate first clean the residue of dough, then with a soft sponge and warm water accurately clean the pan, the spiral the dough breaker and the mobile protection, dry with kitchen paper, then pass over the parts just mentioned then all the machine with a smooth and cleaned cloth with a specific cleaning product for food machines.

⚠ WARNING

We recommend not to use any kind of chemical product abrasive or corrosive. Absolutely avoid using running water, different tools, rough or abrasive objects, metal wool, sponges etc. which can damage the surfaces and be dangerous from an hygienic point of view. To maintain the efficiency and security of the machine it is necessary to proceed with periodical maintenance (every 6 months) of the following indications:

5.2 Tensioning of the upper chain

The chain must be tensioned if, by checking it, it becomes loose or if the rotation of the spiral is not constant. Unscrew the panel P, (PICT. 14) loosen the screws Q, pull the support of the spiral R as far as the tension of the chain is optimized, lock the support R with the screws Q, put the panel P on once more and fix it.

PICT. 14-15

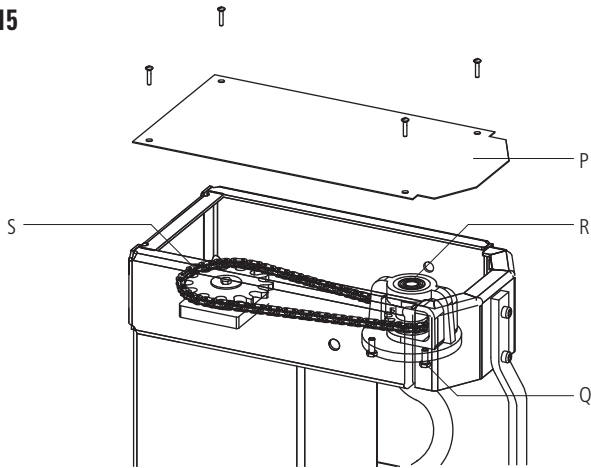

5.3 Lubricating the chains

After unscrewing the fixing screws, take away the upper P and the back V panels, put on the chains S-T (PICT. 15-16) a reasonable amount of proper grease, sufficient to lubricate all the links of the chain. Once this is done, mount the two panels and secure again with screws.

PICT. 16

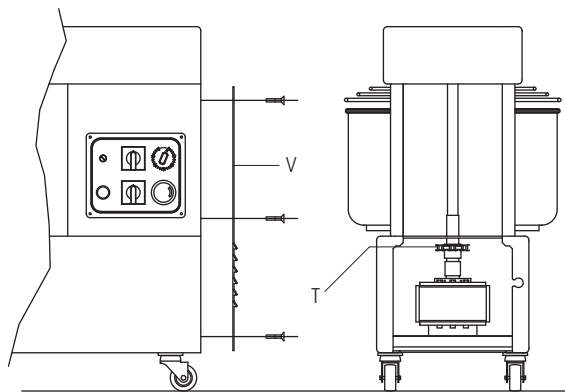

5.4 Possible anomalies

ANOMALY	CAUSE	SOLUTION
The machine does not start	<ul style="list-style-type: none"> • Lack of energy in the power grid • The Emergency stop button in blocked • The protection grid and/or the top are up • The knob of the general switch is in position 0 • The knob of the speed selector is in position 0 • The timer is in position 0 	<ul style="list-style-type: none"> • Check the general switch, the plug, the tap and the feeding cable • Rotate the button following the direction of the arrow • Put down correctly both the grid and the top • Rotate the knob in position 1 • Rotate the knob in position 1 or 2 • Rotate the knob of the timer from 1 to 30 minutes
The spiral turns incostantly	<ul style="list-style-type: none"> • The chain is loose 	<ul style="list-style-type: none"> • Stretch the chain following the instructions at par. 5.2
The machine stops while working	<ul style="list-style-type: none"> • Stop of the fuse 	<ul style="list-style-type: none"> • Change the fuse with another on which has the same characteristics

CHAPTER 6 | DEMOLITION OF THE MACHINE

In case of dismantelling and demolition of the machine, the pieces which the machine is made of, do not present any kind of danger that necessitates any particular caution. To facilitate the recycling process of the materials, you must separate all electrical components.

CHAPTER 7 | AFTER SALE SERVICE

7.1 Spare parts

For a demand of spare parts, see the PICT. 17-22.

WARNING

We advise you to fit original spare parts only.

EEC countries:

Contact exclusively place of purchase.

FIG. 17 Parti di ricambio impastatrice con testa e vasca fissa mod. IM 5-8 **FIG. 17** Pièces de rechange pour pétrisseuse avec tête et cuve fixe mod. IM 5-8
PICT. 17 Spare parts for mixer with fixed top and bowl mod. IM 5-8 **BILD 17** Ersatzteile für die Teigknetmaschine mit gestern Kopf und Becken mod. IM 5-8

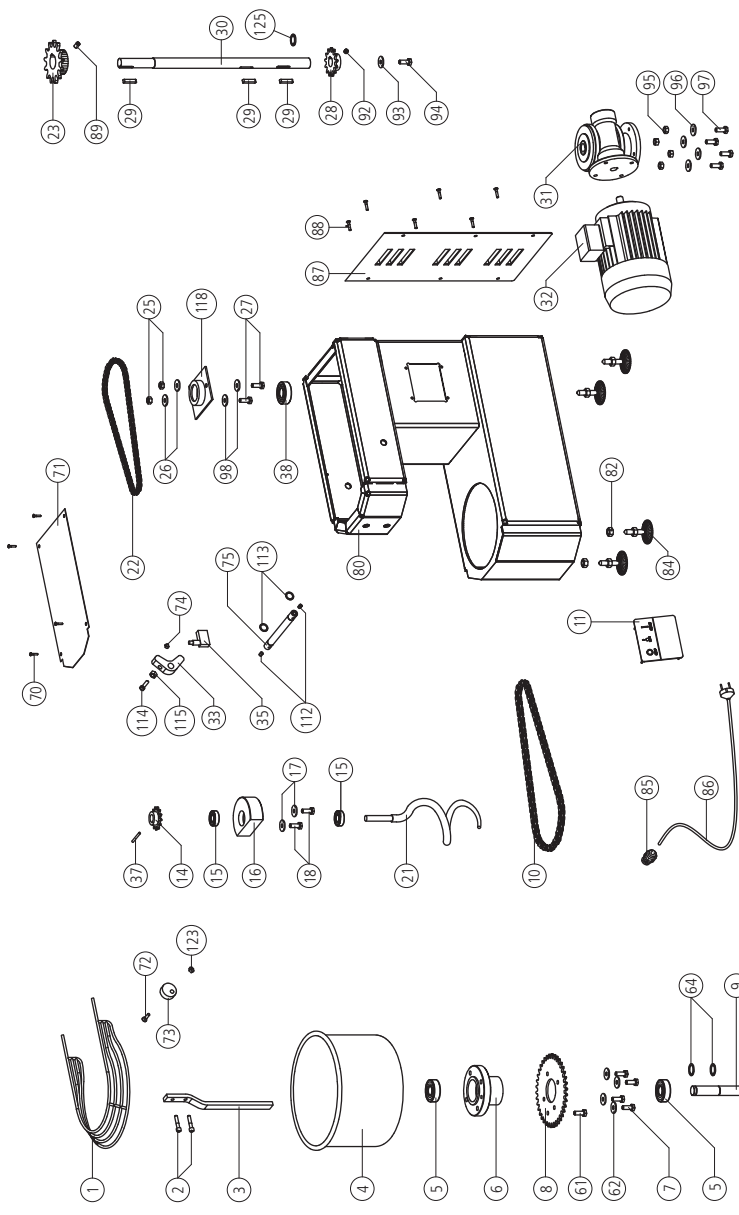

FIG. 18 Parti di ricambio impastatrice con testa e vasca fissa mod. IM 12-18 **FIG. 18** Pièces de rechange pour pétrisseuse avec tête et cuve fixe mod. IM 12-18
PICT. 18 Spare parts for mixer with fixed top and bowl mod. IM 12-18 **BIELD 18** Ersatzteile für die Teigknetmaschine mit gestern Kopf und Becken mod. IM 12-18

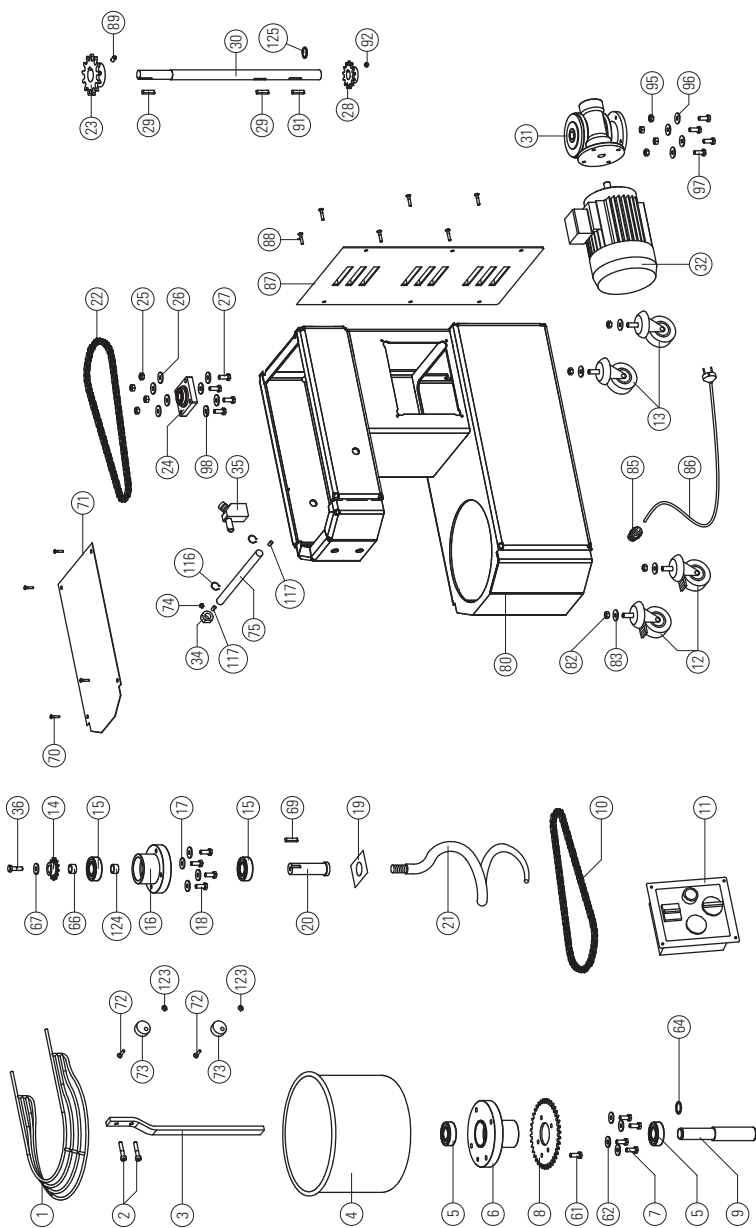

FIG. 19 Parti di ricambio impastatrice con testata e vasca fissa mod. IM 25-38-44
PICT. 19 Spare parts for mixer with fixed top and bowl mod. IM 25-38-44

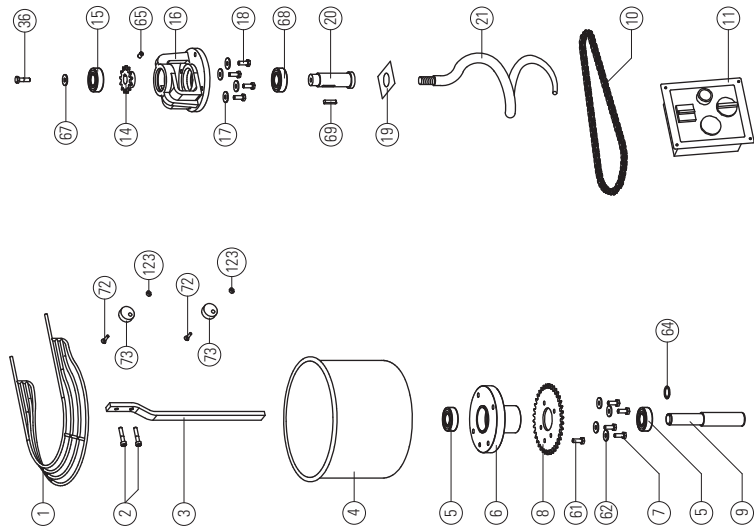

FIG. 19 Pièces de rechange pour pétrisseuse avec tête et cuve fixe mod. IM 25-38-44
BILD 19 Ersatzteile für die Teigmietmaschine mit gestern Kopf und Becken mod. IM 25-38-44

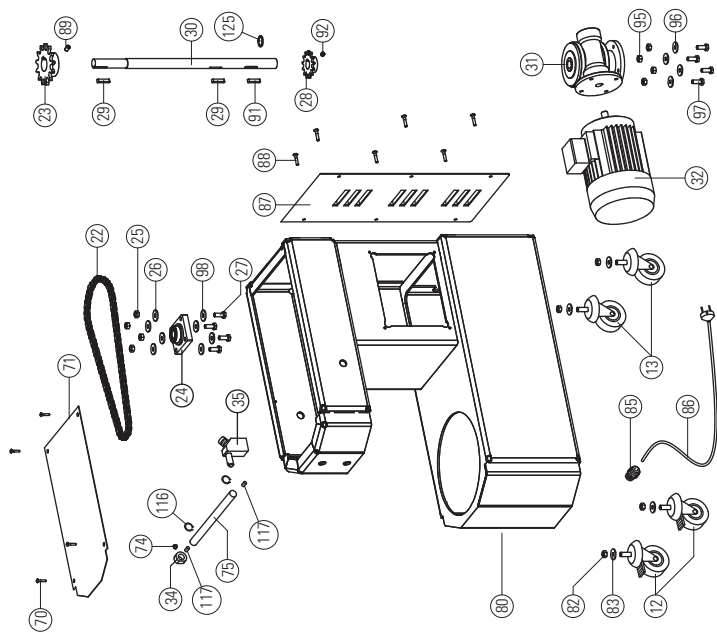

FIG. 20 Parti di ricambio impastatrice con testa e vasca fissa mod. IM 60 **FIG. 20** Pièces de rechange pour pétrisseuse avec tête et cuve fixe mod. IM 60
PICT. 20 Spare parts for mixer with fixed top and bowl mod. IM 60 **BILO 20** Ersatzteile für die Teigmiet-maschine mit gestern Kopf und Becken mod. IM 60

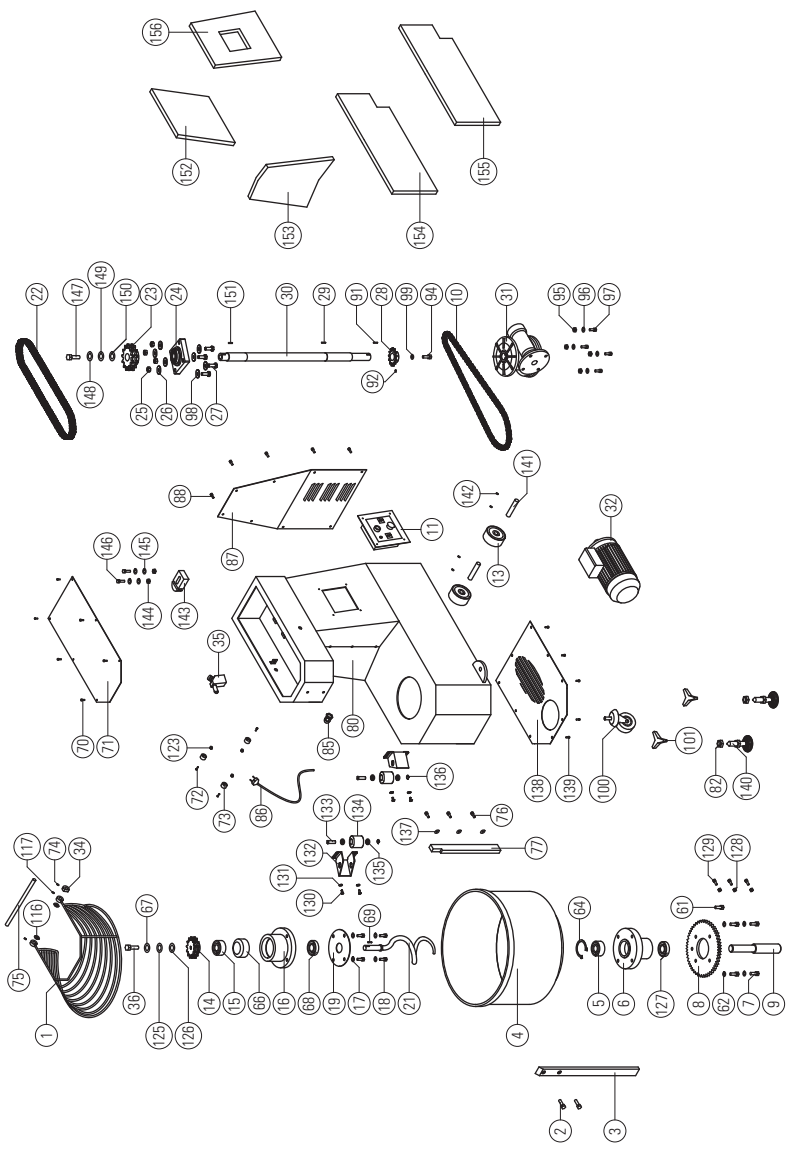

FIG. 21 Parti di ricambio impastatrice con testa sollevabile e vasca estraibile mod. IM 12-18 A **FIG. 21** Pièces de rechange pour pétrisseuse avec tête soulevable et cuve extractible mod. IM 12-18 A
PICT. 21 Spare parts for mixer with raising top and removable bowl mod. IM 12-18 A **BILD 21** Ersatzteile für die Teigmietmaschine mit hebbarem Kopf und herausziehbarem Becken mod. IM 12-18 A

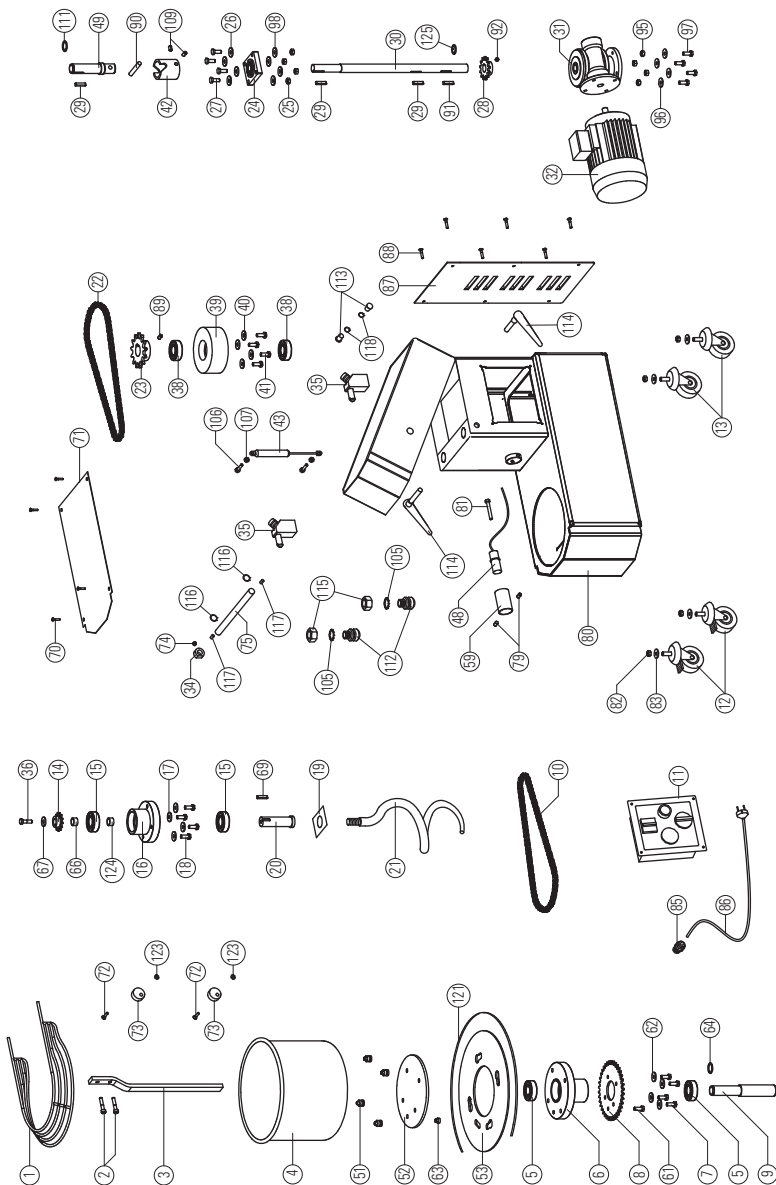
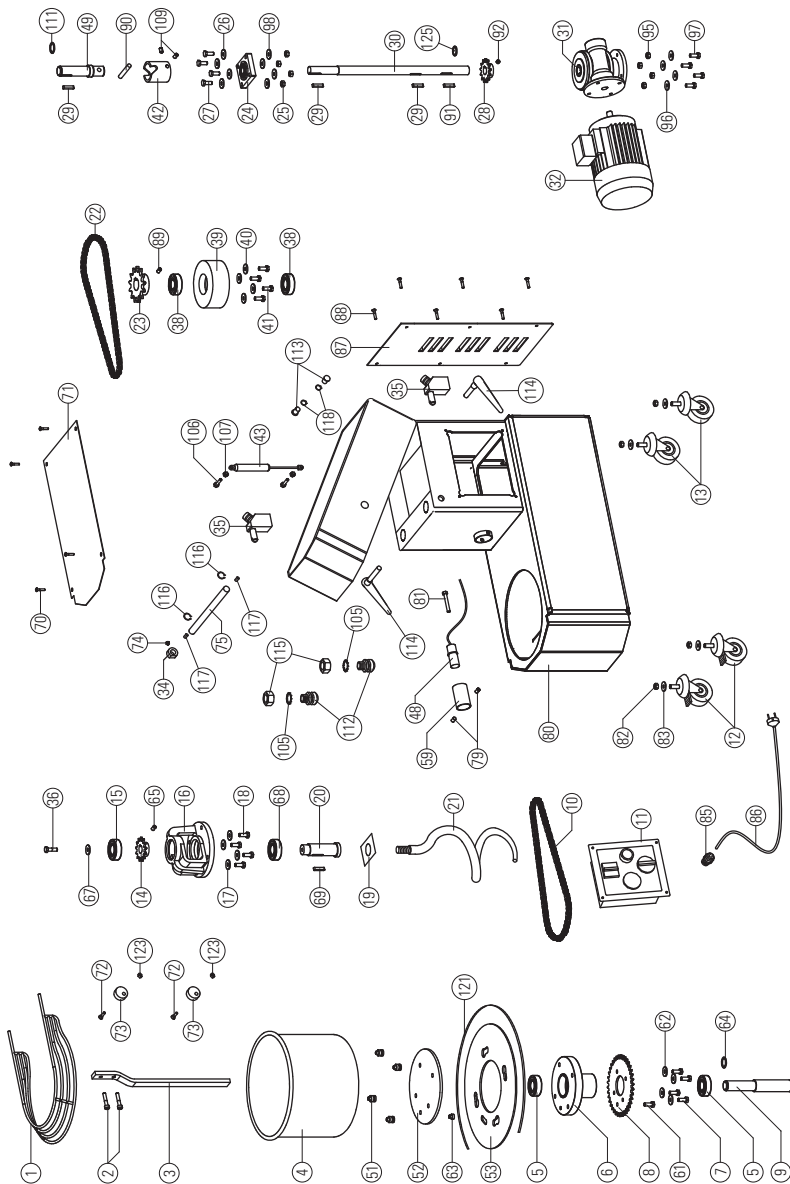

FIG. 22 Parti di ricambio impastatrice con testa sollevabile e vasca estraibile mod. IM 25-38-44 A **FIG. 22** Pièces de rechange pour pétrisseuse avec tête soulevable et cuve extractible mod. IM 25-38-44 A
PICT. 22 Spare parts for mixer with raising top and removable bowl. mod. IM 25-38-44 A **BILD 22** Ersatzteile für die Teigknetmaschine mit hebbarem Kopf und herausziehbarem Becken mod. IM 25-38-44 A



RIF.	DESCRIZIONE
1	PROT. VASCA
2	BULLONE ASTA ROMPIPASTA
3	ASTA ROMPIPASTA
4	VASCA
5	CUSCINETTO SUPPORTO VASCA
6	SUPPORTO VASCA
7	BULLONE CORONA VASCA
8	CORONA
9	ALBERO VASCA
10	CATENA VASCA
11	IMPIANTO ELETTRICO
12	RUOTA CON FRENO
13	RUOTA SENZA FRENO
14	PIGNONE SUPPORTO SPIRALE
15	CUSCINETTO SUPPORTO SPIRALE
16	SUPPORTO SPIRALE
17	RONDELLA
18	BULLONE
19	DISCO PROTEZIONE
20	ALBERO SUPPORTO SPIRALE
21	SPIRALE
22	CATENA SPIRALE
23	PIGNONE
24	SUPPORTO UCF ALBERO RIDUTTORE
25	DADO
26	RONDELLA
27	BULLONE
28	PIGNONE CATENA VASCA
29	CHIAVETTA
30	ALBERO RIDUTTORE
31	RIDUTTORE

RIF.	DESCRIZIONE
32	MOTORE
33	TRIANGOLO
34	AZIONATORE FINE CORSA
35	MICRO
36	BULLONE
37	-
38	CUSCINETTO
39	SUPPORTO TESTATA
40	RONDELLA SUPPORTO TESTATA
41	BULLONE SUPPORTO TESTATA
42	GIUNTO DI TRASMISSIONE
43	MOLLA A GAS
44	-
45	-
46	-
47	-
48	SENSORE DI PROSSIMITÀ VASCA
49	ALBERO TESTATA
50	-
51	PIEDE FISSAGGIO VASCA
52	DISCO FISSO
53	DISCO MOBILE
54	-
55	-
56	-
57	-
58	PROTEZIONE MICRO
59	SUPPORTO SENSORE VASCA
60	-
61	BULLONE FERMA CORONA
62	RONDELLA CORONA VASCA

RIF.	DESCRIZIONE
63	FERMO BATTUTA DISCO MOBILE
64	SEGER ALBERO VASCA
65	GRANO PIGNONE SPIRALE
66	DISTANZIALE SUPPORTO SPIRALE
67	RONDELLA
68	CUSCINETTO SUPPORTO SPIRALE
69	CHIAVETTA ALBERO SPIRALE
70	VITE AUTOFORANTE CARTER TESTATA
71	CARTER TESTATA
72	VITE PER FERMO GRIGLIA
73	FERMO GRIGLIA
74	GRANO AZIONATORE FINE CORSA/TRIAN.
75	ALBERO GRIGLIA
76	
77	PROTEZIONE VASCA
78	
79	GRANO SUPP. SENS. VASCA
80	TELAIO
81	VITE REGOLAZIONE SENSORE VASCA
82	DADO RUOTA/PIEDE
83	RONDELLA NYLON RUOTA
84	PIEDE REGOLABILE
85	PRESSACAVO PER CAVO ALIMENTAZIONE
86	CAVO ALIMENTAZIONE
87	CARTER POSTERIORE
88	VITE AUTOFORANTE CARTER POST.
89	GRANO
90	SPINA ACCIAIO ALBERO TESTATA
91	CHIAVETTA
92	GRANO PIGNONE CATENA VASCA
93	RONDELLA FISS. ALBERO RIDUTT.

RIF.	DESCRIZIONE
94	BULLONE FISSAGGIO ALBERO RIDUTT.
95	DADO FISSAGGIO RIDUTTORE
96	RONDELLA FISSAGGIO RIDUTTORE
97	BULLONE FISSAGGIO RIDUTTORE
98	RONDELLA
99	RONDELLA FISS. ALBERO RIDUTT. 10 X 40
100	RUOTA
101	VOLANTINO
102	
103	
104	
105	RONDELLA
106	BULLONE MOLLA A GAS
107	DADO AUTOBLOCCANTE MOLLA A GAS
108	
109	GRANO GIUNTO DI TRASMISSIONE
110	CHIAVETTA
111	SEGER ALBERO TESTATA
112	PIEDE SERR. TESTATA
113	PERNO CERR. TESTATA
114	MANIGLIA SERR. TESTATA
115	DADO
116	SEEGER
117	GRANO
118	SEEGER
119	
120	
121	GOMMA DISCO MOBILE
122	
123	DADO PER FERMO GRIGLIA
124	DISTANZIALE CUSCINETTO SUPP. SPIRALE

RIF.	DESCRIZIONE
125	ANELLO DI BATTUTA
126	RONDELLA
127	CUSCINETTO SUPPORTO VASCA
128	DADO
129	BULLONE
130	BULLONE
131	RONDELLA
132	SUPPORTO RULLO
133	MOZZO RULLO
134	RULLO
135	CUSCINETTO
136	SEGER
137	RONDELLA
138	PROTEZIONE INFERIORE
139	VITE AUTOFORANTE PROTEZIONE INFERIORE
140	PIEDE ANTERIORE

RIF.	DESCRIZIONE
141	MOZZO RUOTA
142	GRANO
143	TENDICATENA
144	DADO
145	RONDELLA
146	BULLONE
147	BULLONE
148	RONDELLA
149	RONDELLA
150	RONDELLA
151	CHIAVETTA
152	FONOASSORBENTE TRONCO SX
153	FONOASSORBENTE TRONCO CENTRALE
154	FONOASSORBENTE CASSONE SX
155	FONOASSORBENTE CASSONE DX
156	FONOASSORBENTE TRONCO DX



I **IMPASTATRICE A SPIRALE**
SERIE IM
Manuale d'uso e manutenzione
Edizione 04-09

GB **SPIRAL MIXER**
MODEL IM
Operating manual
Edition 04-09

F **PÉTRIN À SPIRALE**
MODÈLE IM
Manuel d'utilisation
Édition 04-09

D **SPIRALTEIGKNETMASCHINE**
MODELL IM
Bedienungsanleitung
Auflage 04-09